

C-Bus™ Saturn™ DLT™ Keypads

C-Bus™ Saturn™ Dynamic Labeling Technology (DLT™) Keypads combine a Saturn style glass cover plate, programmable keypad buttons, and easily customized labels on a backlit LCD screen that eliminates the need for custom labels.

These keypads are designed to be easy to install, customize, and use. By virtue of the variety of button configurations available, one compact Saturn Keypad with DLT can take the place of many single-operation switches, ON/OFF toggles, dimmers, and timers. The five keypad buttons are lit with cool blue LEDs that complement the keypad's sleek lines and show the status of controlled devices.

> Features

- Button configurations include multi-point switching and dimming master ON/OFF switching, and scene settings
- Keypads have five physical buttons - four control buttons and one scroll/page button combined with two screens of labels, for a total of eight controllable buttons
- Scene control includes up to ten group addresses per scene and four scenes per keypad
- Independent timers available for each button
- Time clock can be displayed at the bottom of the screen
- Locator LED can illuminate the keypad, helping a user find it in dim light
- Displays up to 8 languages from a set of more than 65

> Functional Aesthetics

- 64 x 128 pixel LCD screen with a white backlight
- Dynamic graphic displays, such as bar graphs, can be enabled or disabled
- Editable LCD labels, available for each button or control group, can display text, symbols, and graphics

> Distributed Intelligence

- Compatible with all C-Bus™ devices and Powerlink® NF3000G3C controllers
- Configured by using Learn Mode or C-Bus™ Toolkit software



Figure 1: Saturn DLT Keypad

Make the most of your energy SM

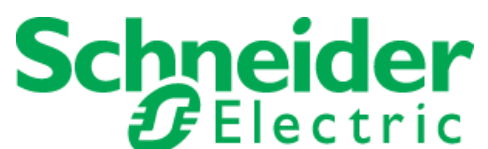

Keypad Ordering (Order face plates separately)

Order numbers for the Saturn DLT keypads include the stock number (SLC5085DL) and the code for the color of the cover plate: Black (BK), Mocha (BR), White (WE) and Cream (CM) For example, SLC5085DLBR represents a complete catalog number for a Saturn DLT keypad with a mocha cover plate. Additional faceplates are available and are sold separately. NOTE: Stainless Steel faceplates can only be purchased separately.

Faceplate Ordering (Order keypads separately)

Order numbers for the Saturn DLT faceplates include the stock number (SLC5085DLF) and the code for the color of the cover plate: Black (BK), Mocha (BR), White (WE), Cream (CM), and Stainless Steel (SS). For example, SLC5085DLFSS represents a complete catalog number for a stainless steel Saturn DLT faceplate.

Figure 2: Saturn DLT Keypad Dimensions

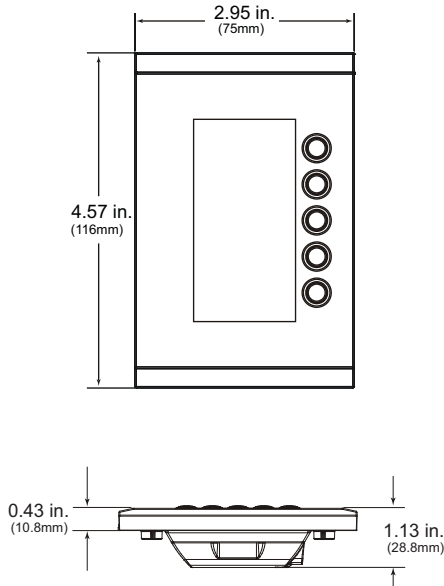

> Specifications

Saturn™ DLT™ Style Keypad

Voltage Requirements	15–36 V DC @ 22 mA required for normal operation, drawn from the C-Bus™ network
Number of Units on a Network	Determined with the C-Bus Calculator, a software utility used to evaluate the total network current load
Electrical Isolation	3.75 kV RMS from C-Bus to power (provided externally)
Control Functions	Load switching, dimming, timing, scene control
Status Indicators	Blue, one dimmable LED per button
Locator Option	User-configurable, adjustable LED to help locate the unit in darkness, has "ignore first button press" option
Scene Control	Up to 40 group addresses. For example, 1 scene can have 40 addresses, or 8 scenes can have 5 addresses each.
Timers	1 sec–18 hr, 1 sec intervals
C-Bus™ Connection	One terminal block to accommodate 24-16 AWG (0.2–15 mm ²), CAT 5 UTP cable required
Response Time	200 msec or less
Dimensions	4.57 in. (L) x 2.95 in. (W) x 1.2 in. (D) [116 mm (L) x 75 mm (W) x 30 mm (D)]
Mounting	Plaster mud ring/Single gang box w/minimum internal width 2.05 in. (52 mm) (not provided)
Weight	5.29 oz (150 g)
Operating Environment	Temp.: 32°F to 113°F (0°C to 45°C) RH: 95%, noncondensing
Standards	UL: Listed 916 Energy Management Equipment CSA 22.2 Spec 205 Signal Equipment FCC: Part 15.101, Class B Digital Device EN61000-4-2 Immunity to ESD
Keypad Assembly Color Options	White, cream, black, and mocha
Keypad Faceplate Color Options	White, cream, black, stainless steel, and mocha

> Order Information

Description	Catalog Number
Saturn DLT Keypad with coverplate	SLC5085DL(xx)*
Additional Faceplates	
DLT Faceplate	SLC5085DLF(xx)*

*(xx) designates color

Schneider Electric USA, Inc.
320 Tech Park Drive, Suite 100
La Vergne, TN, 37086
1-888-778-2733
www.schneider-electric.us

1250HO0506R0610
Administrator

Schneider Electric and logo and "Make the most of your energy" are trademarks or registered trademarks of Schneider Electric and/or its affiliates in the United States and/or other countries. Other trademarks used herein are the property of their respective owners.